

# SOLAR LED ENHANCED ROAD SIGNS (STOP)



## Features

Solar LED enhancing road signs is a simple and effective way to increase the visibility of the message and improve the safety of pedestrians and vehicles. The innovative technology employs a set of synchronised ultra-bright reflective backed LEDs that operate day and/or night and are visible up to 2000 metres. A solar panel connected to high-quality lithium-ion battery allows > 72 hours of LED operation from a single full charge. The road signs offered are manufactured to Australian standards from aluminium and 3M reflective material and attach to standard 60mm galvanised signposts to provide efficient and effective visual enforcement.

Signs manufactured to Australian Standards

Increase the visibility of the message and improve safety

Automatic dusk to dawn operation

> 5 nights autonomy

IP65 Waterproof design

Day and/or night operation

Quality Lithium- ion battery

Simple to install - Secures to a standard 60mm sign post

Alternative regulatory signs available

Efficient and effective visual enforcement

2 year warranty for faulty workmanship or component failure not influenced by external means



Luminaire Height Variable

Lumen Output 500 lm

LED Output 3.6W

# SOLAR LED ENHANCED STOP SIGN SPECIFICATION

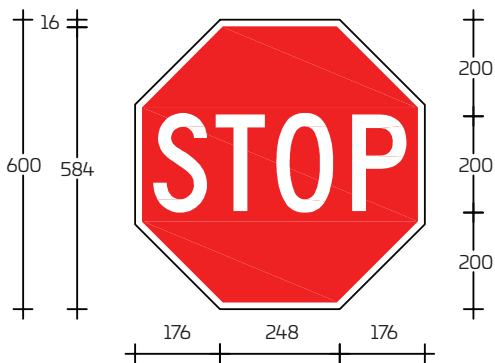
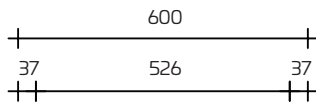
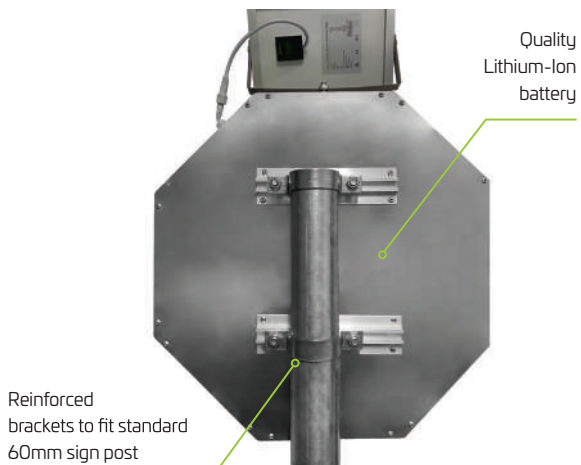
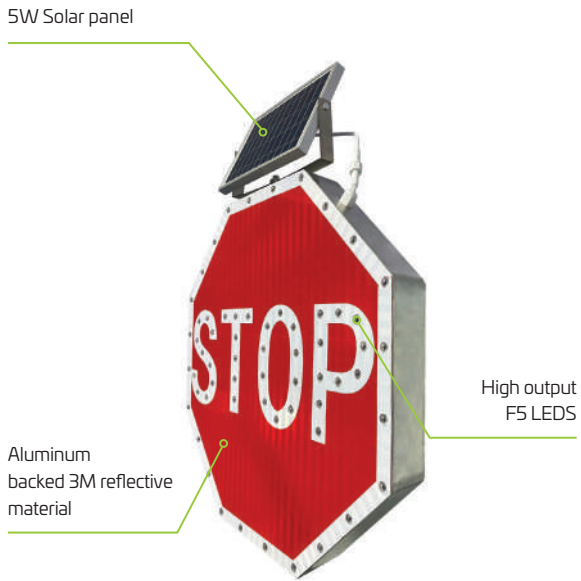

R1-1(A)

## Technical Data

Solar Panel Wattage	5W
LED Output	3.6W
Lumen Output	500 lm
Battery Type	Lithium-ion
Battery Specifications	8.8AH 3.7V (32.56Wh)
Autonomy	> 5 nights
Correlated Colour Temp (CCT)	620k (Red)
Fixture Size	600x600x65mm
Light Source	Epistar F5 LED
Recharge	6 hours
Mounting Height	Various
Mounting	Wall or post
Finish	Aluminum/3M reflective material
Warranty Period	2 years
SKU	SSR1-1A

## Mode of Operation

Remote controllable selection of flashing dusk to dawn or constant 24 hour operation. Alternative modes of operation are available on request.

## Also Available



As we continue to improve the products function and/or design specifications and data provided may change without notice. Errors and omissions accepted.