

Design | Manufacture | Supply | Install

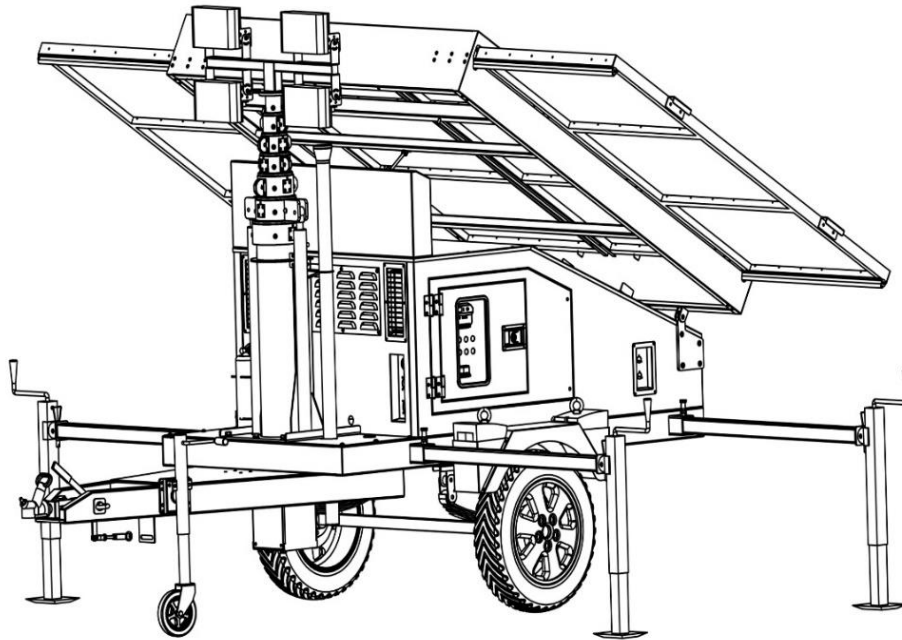

OPERATION MANUAL



SOLAR LIGHTING DESIGNS TRAILER LIGHTING TOWER

THIS MANUAL MUST ACCOMPANY THE EQUIPMENT AT ALL TIMES.

INTRODUCTION

This manual provides information and procedures to safely operate and maintain the solar lighting tower. For your own safety and protection from physical injury, carefully read, understand, and observe the safety instructions described in this manual. *The information contained in this manual was based on machines in production at the time of publication.*

DO NOT MODIFY or use this equipment for any application other than which it was designed for.

Keep a copy of this manual with the unit at all times. Operators manual for solar controller, inverter, battery charger and backup generator were also supplied with the unit at the time of shipment from the factory. The manual provides detailed operation and maintenance procedures.

Unit Model Number: _____
Unit Serial Number: _____

TABLE OF CONTENTS

Page

INTRODUCTION	1
TABLE OF CONTENTS	2
SAFETY NOTES	3
OPERATING SAFETY	3
SERVICE SAFETY	4
TOWING SAFETY	4
UNIT SERIAL NUMBER LOCATIONS	5
TRANSPORTING SAFETY	5
SAFETY SYMBOL SUMMARY	6
SOLAR TOWER SET UP	7
SOLAR PANELS SLIDING OUT	8-9
RASING THE TOWER	10-12
SOLAR PANELS RETRACT	13-14
LOWER THE MAST	15-17
ELECTRICAL CIRCUIT DIAGRAM	18
HYDRAULIC ELECTRICAL CIRCUIT DIAGRAM	19
TAILLIGHT DIAGRAM	20

SAFETY NOTES



This is the safety alert symbol. It is used to alert you to potential personal injury hazards. Obey all safety messages that follow this symbol to avoid possible injury or death.

This manual contains DANGERS, WARNINGS, CAUTIONS, NOTICES and NOTES which must be followed to prevent the possibility of improper service, damage to the equipment, personal injury, or death. The following formatting options will apply when calling the reader's attention to the DANGERS, WARNINGS, CAUTIONS, NOTICES and NOTES.

⚠ DANGER

INDICATES A HAZARDOUS SITUATION WHICH, IF NOT AVOIDED, WILL RESULT IN DEATH OR SERIOUS INJURY.

⚠ WARNING

Indicates a hazardous situation which, if not avoided, could result in death or serious injury.

⚠ CAUTION

Indicates a hazardous situation which, if not avoided, may result in minor or moderate injury.

NOTICE

Indicates a hazardous situation which, if not avoided, may result in property or equipment damage.

Note: Notes contain additional information important to a procedure and will be found within the regular text body of this manual.

OPERATING SAFETY



Before using the solar tower, be sure you read and understand all of the instructions! This equipment was designed for specific applications; DO NOT modify or use this equipment for any application other than which it was designed for. Equipment operated improperly or by untrained personnel can be dangerous! Read the operating instructions and familiarize yourself with the location and proper use of all instruments and controls. Inexperienced operators should receive instruction from someone familiar with the equipment before being allowed to operate or set up the solar tower. The following points should be practiced at all times:

- The area immediately surrounding the solar tower should be dry, clean, and free of debris.
- Position and operate the solar tower on a firm, level surface.
- **NEVER** operate a unit in need of repair.
- Lower tower when not in use, or if high winds or electrical storms are expected in the area.
- Make certain light tower is well grounded and securely fastened to a good earthen ground.
- When the mast is raising, make sure area above light is open and clear of overhead wires and obstructions.
- Keep area beside trailer clear of people while raising and lowering mast!
- Trailer must be leveled and outriggers extended before raising tower. Outriggers must remain extended while tower is up.
- If for any reason any part of mast hangs up or winch cable develops worn while raising or lowering tower, STOP immediately and replace it.
- **NEVER** remove safety pin or pull mast locking pin while tower is up!
- **NEVER** use tower if insulation on electrical cord is cut or worn through.
- If used in dense crowds, please set up guards 5 meters away from the unit.
- **NEVER** take power directly from the batteries.

OPERATING SAFETY

- If not being used for a long time, please turn off the breaker for the batteries.
- During mast extending, once the hole for locking pin aligns, stop operating the manual/electric winch.
- During solar charge process, do not unplug each panels and the connectors for solar input on the trailer. It will lead to severe personal injury and equipment damage.
- **NEVER** put conductive metal objects on the batteries.
- Do not forget to insert the safety locking pin when cranking up the outrigger.

SERVICE SAFETY



This unit includes solar modules and batteries which are with high voltage circuits capable of causing serious injury or death. Only a qualified electrician should troubleshoot or repair electrical problems occurring in this equipment.

- Before servicing solar tower, make sure the breakers for solar modules, batteries and lights are turned OFF. Disconnect the solar panels and batteries.
- **NEVER** allow water to accumulate around the base of the tower.
- **NEVER** wash the unit with a power washer or high pressure hose.
- Please wear goggles and insulating gloves, using insulation wrench to replace the batteries.
- **NEVER** disassemble and repair the mast in uneven place. The mast must be hung and installed with equipment.
- **NEVER** replace the tyres and outriggers or adjust and fix the brake system in uneven place.
- **NEVER** replace the manual (electric/hydraulic cylinder) winch when the mast is extending.
- Make sure slings, chains, hooks, jacks, and other types of lifting devices are attached securely and have enough weight-bearing capacity to lift or hold the equipment safely. Always remain aware of the position of other people around you when lifting the equipment.
- N46 antiwear hydraulic oil is recommended and needs to be replaced once a year, while the replacement for the first time should not be more than 3 months.
- Regularly fill hydraulic cylinder with lubricant and keep clear of the exposed part.

TOWING SAFETY



Towing a trailer requires care! Both the trailer and vehicle must be in good condition and securely fastened to each other to reduce the possibility of an accident. Also, some countries require that trailers be registered and licensed. Contact your local Department of Transportation office to check on license requirements for your particular unit.

- Check that the hitch and coupling on the towing vehicle are rated equal to, or greater than, the trailer's "gross vehicle weight rating" (GVWR).
- Check tires on trailer for tread wear, inflation, and condition.
- Inspect the hitch and coupling for wear or damage. **DO NOT** tow trailer using defective parts!
- Make sure the trailer hitch and the coupling are compatible. Make sure the coupling is securely fastened to the vehicle.
- Connect safety chains in a crossing pattern under the tongue and if the trailer is with electric brake, attach the breakaway cable **TO THE REAR BUMPER OF THE TOWING VEHICLE**. Do not attach the cable to the trailer hitch.
- Make sure directional and brake lights on the trailer are connected and working properly.
- Check that all lug nuts holding wheels on are tight and that none are missing.
- Maximum recommended speed for highway towing is 45 m.p.h (72km/h). Recommended off-road towing speed is not to exceed 10 m.p.h. or less depending on terrain. When towing, maintain extra space between vehicles and avoid soft shoulders, curbs, and sudden lane changes. If you have not pulled a trailer before, practice turning, stopping, and backing up in an area away from heavy traffic. A film of grease on the coupler will extend coupler life and eliminate squeaking. Wipe the coupler clean and apply fresh grease each time the trailer is towed.

UNIT SERIAL NUMBER LOCATIONS

Refer to the locations illustrated below to find the unit ID plate. Important information, such as the unit serial number, GVWR and GAWR for your trailer are found on the plate. Record the information from the plate, so it is available if it is lost or damaged. When ordering parts or requesting technical service information, you may be asked to specify this information.

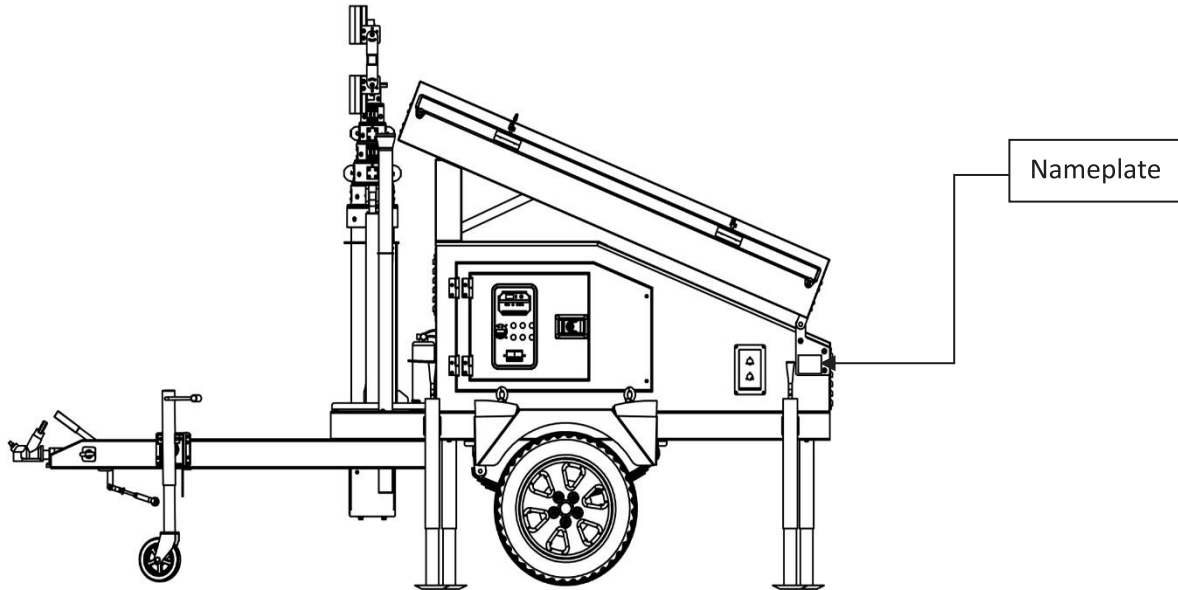





TRANSPORTING SAFETY

CAUTION

- Before lifting, make sure that light tower parts are not damaged and screws are not loosened or lost.
- Always make sure crane or lifting device has been properly secured to lifting hook of the equipment.
- NEVER lift the equipment while light tower is working.
- Make sure the tower is in the stowed position before lifting.
- Always Make sure all solar panel lock is secure before lifting.
- Use adequate lifting cable (wire or rope) of sufficient strength.
- Use one point suspension hook and lift straight upwards.
- Never allow any person or animal to stand underneath the equipment while lifting.
- If lifting through pockets, make sure forks of forklift are inserted in pockets as far as possible before lifting.
- When loading onto flatbed truck, make sure that front jackstand of light tower is retracted and in the horizontal position so that the foot does not make contact with the deck floor.
- DO NOT secure the unit by running a strap or chain over the tongue of the light tower. This may cause severe damage to the unit.
- Straps and chains should be routed through the transport tie-down points located beneath each corner of the cabinet to allow even application of force to the front and rear of the machine.

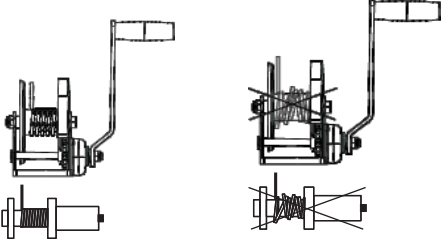
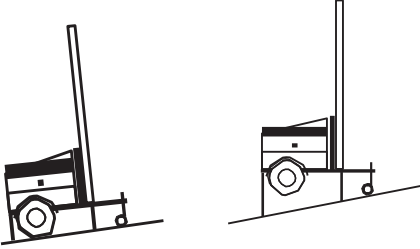
SAFETY SYMBOL SUMMARY

This equipment has been supplied with numerous safety and operating decals. These decals provide important operating instructions and warn of dangers and hazards.

	<p>Always keep tension on steel wires! Slack, may cause wire damage and excessive wear!</p>
	<p>Always make sure trailer is fixed at maintain level when operate light tower.</p>
	<p>Read and understand the supplied operator's manual, Plug Out before operating unit.</p>
	<ul style="list-style-type: none"> ● Crush hazard! A falling top device can cause death or serious injury. ● Crush hazard! A falling mast can cause death or serious injury.
	<ul style="list-style-type: none"> ● Anchor/tie down point. ● Pinch point area.

SOLAR TOWER SET UP

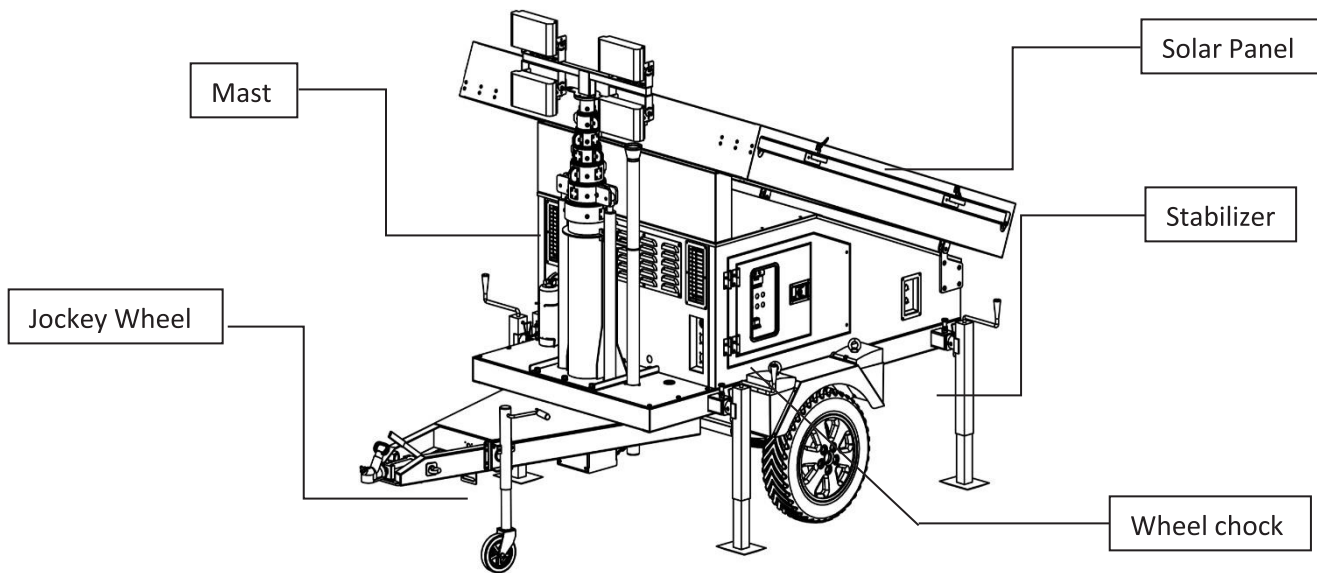

1. For maximum light coverage, locate the unit at ground level or in a spot higher than the area being illuminated by the lamps.

⚠ WARNING

The tower extends up to 24.6 ft (7.5m). Make sure area above the trailer is open and clear of overhead wires and obstructions.

2. Place the trailer on firm ground that is relatively flat. This will make it easier to level the tower. Apply the hand brake and block the wheels on the trailer to keep it from moving.
3. Connect a good earthen ground to the grounding stud on the base of mast.
4. Pull the locking pin on the jockey wheel and rotate it 90° until the spring loaded pin snaps back into place. Turn the jack handle anticlockwise to raise the trailer drawbar off of the towing vehicle.
5. Pull the locking pins on the outriggers and extend each outrigger until the locking pin snaps back into place (A). Pull out the locking pin in the bottom of the outrigger and fit it to the third hole above (B). Apply the same action for the other 3 outriggers. Turn the jack handle clockwise to start leveling the trailer. Adjust all four jacks by turning their handles clockwise until they are firmly in contact with the ground and the trailer is as level as possible (C).

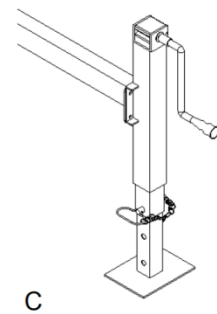
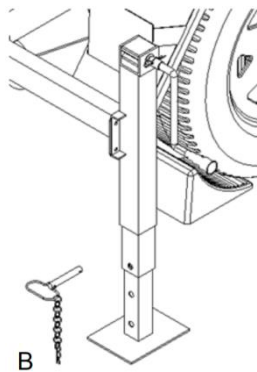
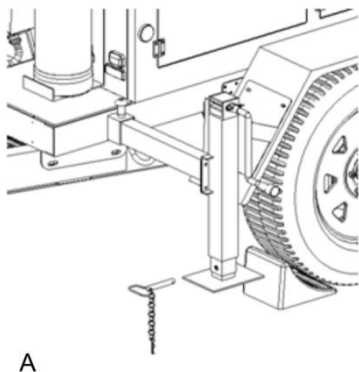

SOLAR PANELS SLIDING OUT

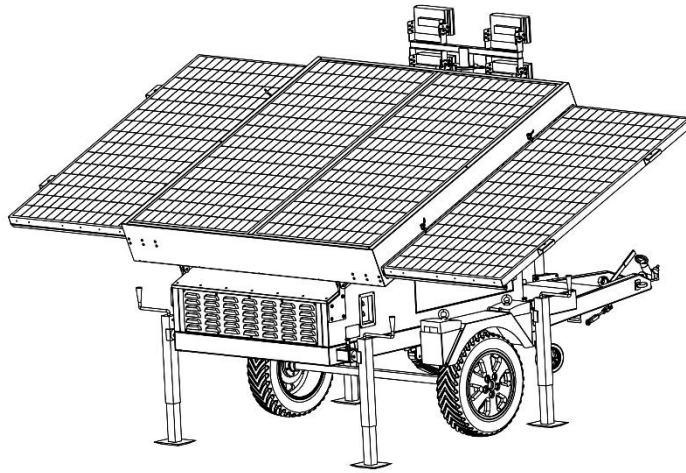

1. Unlock the solar panels (A) open the lock for solar panel (B) and pull the panels to the outermost position and make sure it is locked in place, and lock it

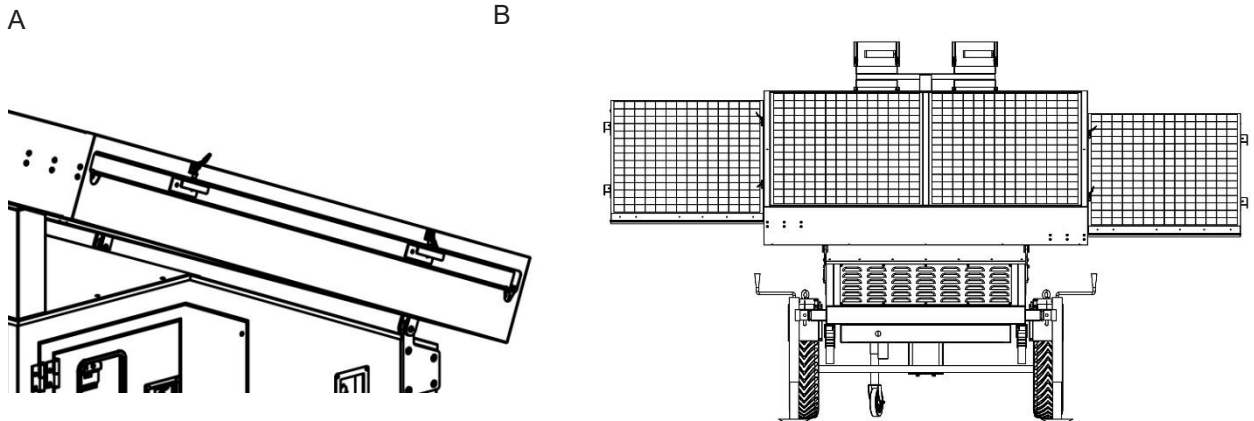

2. Connect the solar panel connectors to those plugs on the cabinet. Turn on the breakers for solar panels and batteries on the control panel.

NOTICE

Under charging condition, make sure the solar panels are faced to the direction of the sun, no shading and the surface is clean.

NOTICE

Do not operate the unit in the dangerous area where there are macadams fly and under weather condition with strong wind. It will damage the solar panels.

⚠ WARNING

Do not unplug the solar panel connectors when it is under charging condition. (It may cause personal injury.)

SOLAR PANELS SLIDING OUT AND ANGLE ADJUSTMENT BY HYDRAULIC ACTUATOR

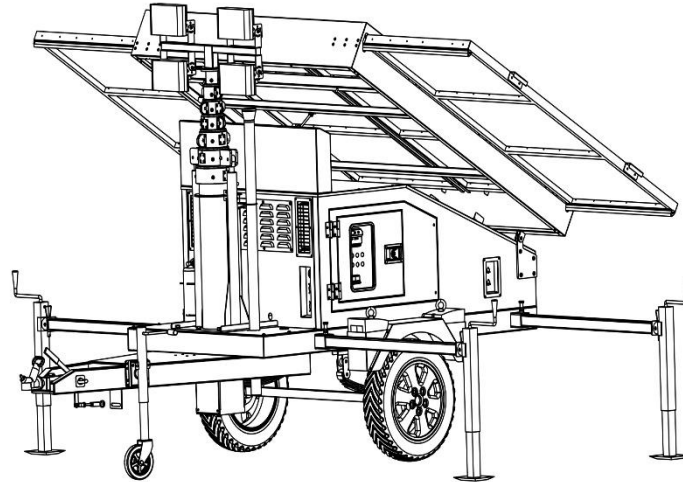

1. Unlock the solar panels (A), press the auto-lock for solar slides (B) and pull the panels to the outermost position and make sure it is locked in place.

A

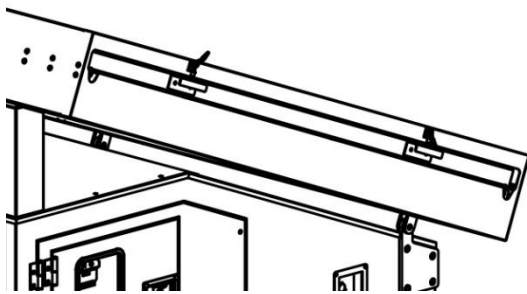

B

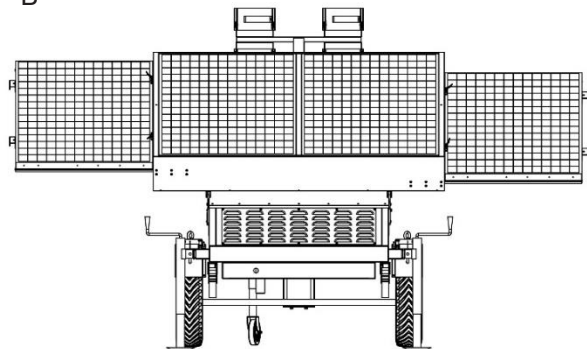

2. Connect the solar panel connectors to those plugs on the cabinet. Turn on the breakers for solar panels and batteries on the control panel.

3. Check hydraulic oil, valve blocks, hydraulic cylinder, hoses and oil joints. Make sure there is no leakage and enough hydraulic oil in the tank. Then press the lifting button on the controller to adjust the solar panels to the required angle.

NOTICE

Under charging condition, make sure the solar panels are faced to the direction of the sun, no shading and the surface is clean.

NOTICE

Do not operate the unit in the dangerous area where there are macadams fly and under weather condition with strong wind. It will damage the solar panels.

⚠ WARNING

Do not unplug the solar panel connectors when it is under charging condition. (It may cause personal injury.)

RAISING THE TOWER

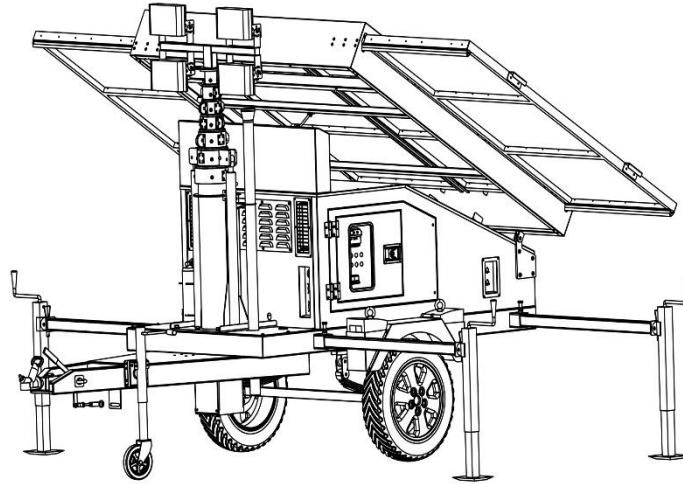

1. Before raising the tower it is necessary to install the top devices and adjust them to the required condition.

▲ WARNING

The trailer must be leveled with the outriggers extended before raising the tower. The outriggers must remain extended while the tower is up. Failure to level the trailer or extend the outriggers will severely reduce the stability of the unit and could allow the tower to tip and fall.

2. Check mast ropes for excessive wear or damage. Make sure the ropes are properly centered in each pulley. Check the mast electrical cord for damage.

▲ WARNING

Do not operate the unit if the insulation on the electrical cord is cut or worn through. Bare wires in contact with the mast or frame may energize the trailer and cause electrocution. Repair or replace cord.

3. Before raising the tower, make sure the steel ropes are orderly and tightened (A). If slack, it will lead to steel ropes wear and even breakage. Crank up the mast clockwise (B) and extend it to the required height. If it is extended to the maximum height. (C). Extend the mast slowly, making sure that the electrical cord is extending at the top sections of the mast. If, for any reason, the cable begins to develop slack or any of the tower sections get stuck, STOP IMMEDIATELY and contact an authorized service center.

A

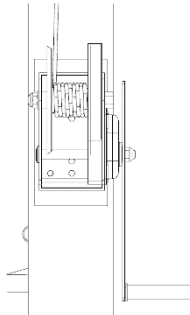

B

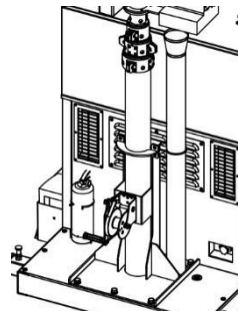

RAISING THE TOWER WITH MANUAL/ELECTRIC LIFTING SYSTEM

1. Set up and level the solar tower as described on page 10
2. Before raising the tower it is necessary to install the top devices and adjust them to the required condition.

⚠ WARNING

The trailer must be leveled with the outriggers extended before raising the tower. The outriggers must remain extended while the tower is up. Failure to level the trailer or extend the outriggers will severely reduce the stability of the unit and could allow the tower to tip and fall.

3. Check mast ropes for excessive wear or damage. Make sure the ropes are properly centered in each pulley.
4. Check the mast electrical cord or hydraulic system for damage.

⚠ WARNING

Do not operate the unit if the insulation on the electrical cord is cut or worn through. Bare wires in contact with the mast or frame may energize the trailer and cause electrocution. Repair or replace cord.

4. Before raising the tower, make sure the steel ropes are orderly and tightened (A). If slack, it will lead to steel ropes wear and even breakage. Then press the extending button on the controller and lift the mast to the required height. When the mast reaches its maximum height, the limit switch will cut the power off automatically. For any reason, the cable begins to develop slack or any of the tower sections get stuck, STOP IMMEDIATELY and contact an authorized service center.

CAUTION

Do not extend the mast beyond the colored mark on top of the lower mast section. On solar tower equipped with the electric winch option, a limit switch on the main mast section will disconnect power to prevent over extending the mast.

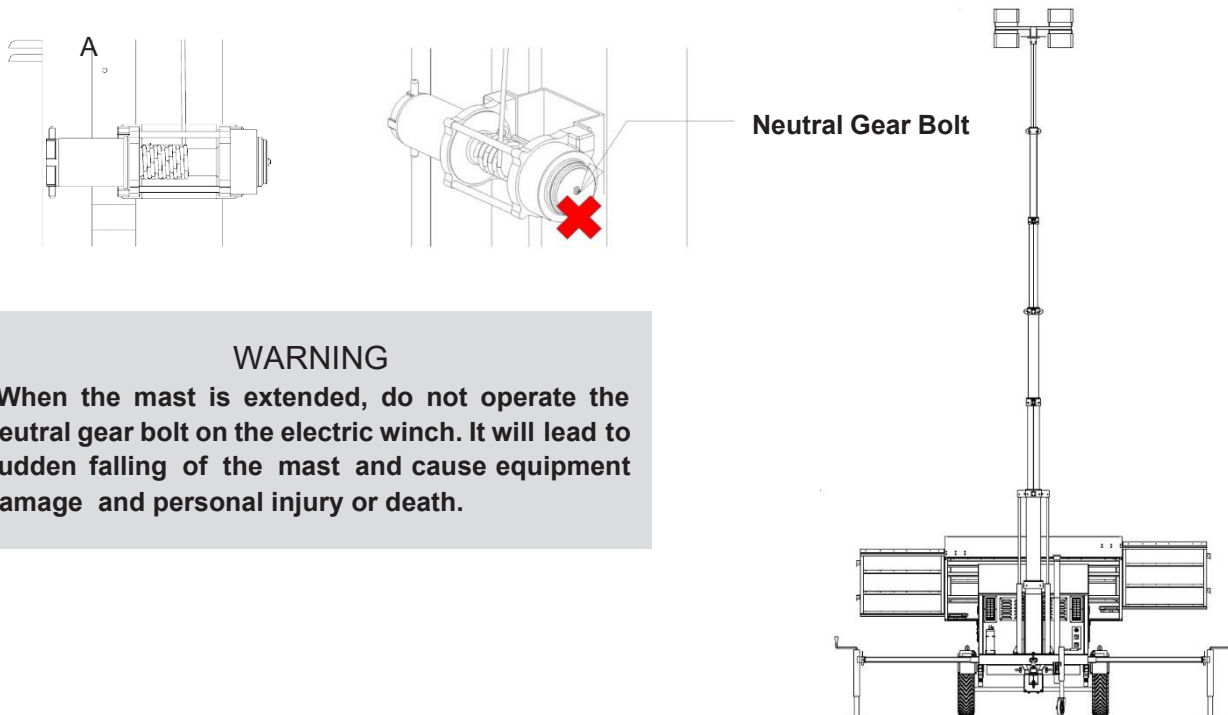

WARNING

When the mast is extended, do not operate the neutral gear bolt on the electric winch. It will lead to sudden falling of the mast and cause equipment damage and personal injury or death.

RAISING THE TOWER WITH HYDRAULIC SYSTEM

1. Set up and level the solar tower as described on page 11
2. Before raising the tower it is necessary to install the top devices and adjust them to the required condition.
3. Check hydraulic oil, valve blocks, hydraulic cylinder, hoses and oil joints. Make sure there is no leakage and enough hydraulic oil in the tank.
4. Check the mast electrical cord for damage.
5. Press the extending button on the controller and lift the mast to the required height. Extend the mast slowly, making sure that the electrical cord is extending at the top sections of the mast. If, for any reason, the cable begins to develop slack or any of the tower sections get stuck, STOP IMMEDIATELY and contact an authorized service center.

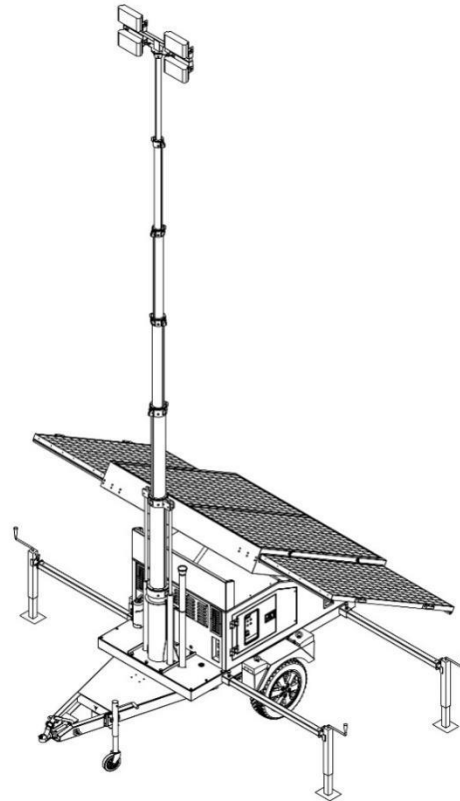

⚠ WARNING

The trailer must be leveled with the outriggers extended before raising the tower. The outriggers must remain extended while the tower is up. Failure to level the trailer or extend the outriggers will severely reduce the stability of the unit and could allow the tower to tip and fall.

⚠ WARNING

Do not operate the unit if the insulation on the electrical cord is cut or worn through.

Bare wires in contact with the mast or frame may energize the trailer and cause electrocution. Repair or replace cord.

SOLAR PANELS RETRACT

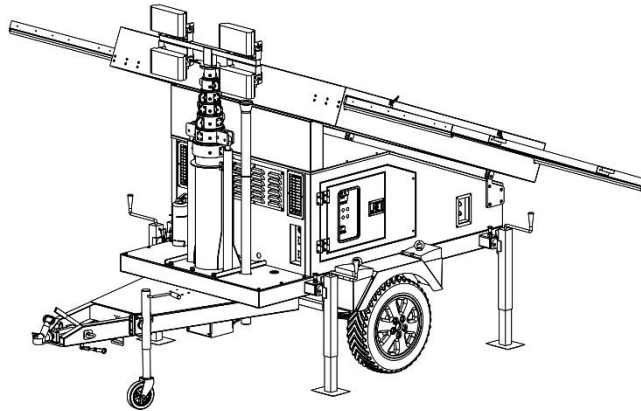

1. Please turn off the breakers for solar panels and batteries. Then disconnect the solar panels with connectors on the trailer enclosure.

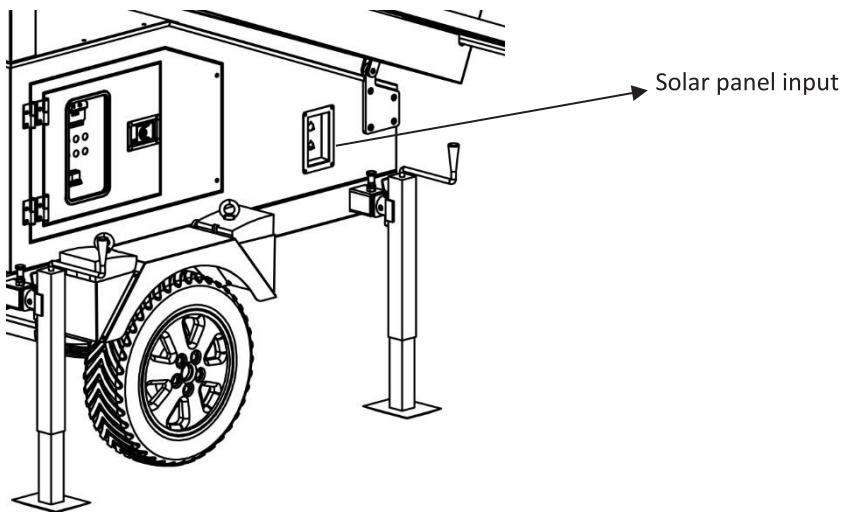

2. Push solar panel into canopy (A), retract the solar panel until it is locked in place (B) and fix the panels by Manual lock (C).

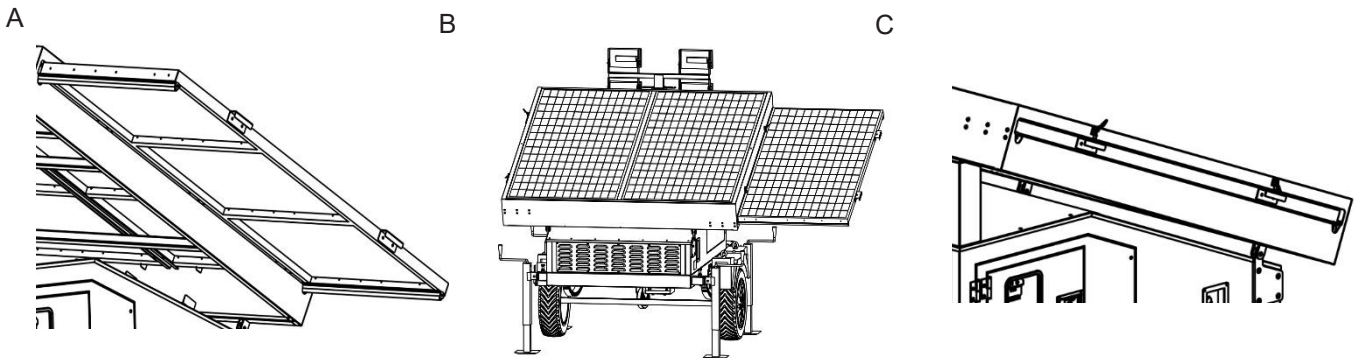

SOLAR PANELS RETRACT AND ANGLE ADJUSTMENT BY LINEAR ACTUATOR

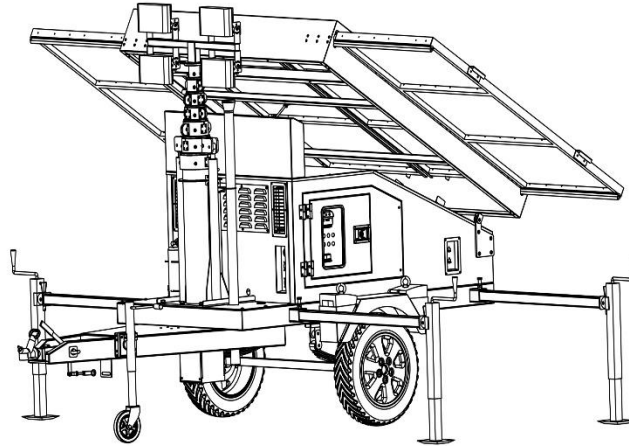

1. Please turn off the breakers for solar panels and batteries. Then disconnect the solar panels with connectors (B) on the trailer enclosure.

⚠ WARNING

Do not unplug the solar panel connectors when it is under charging condition. (It may cause personal injury.)

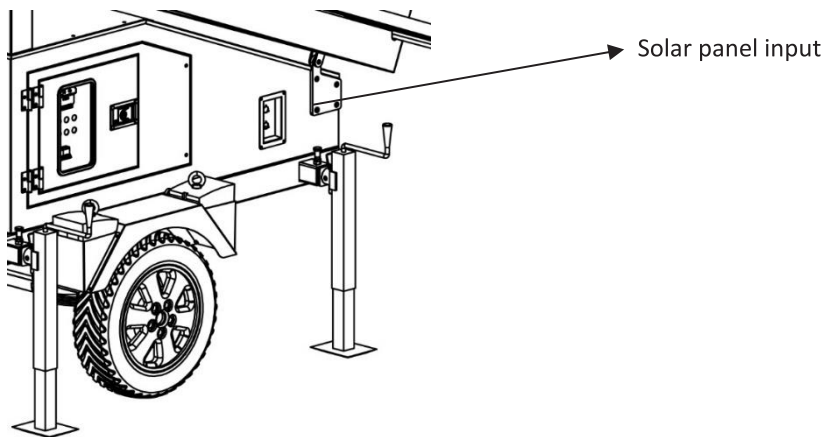

2. Push solar panel into canopy (A), retract the solar panel until it is locked in place (B) and fix the panels by Manual lock (C).

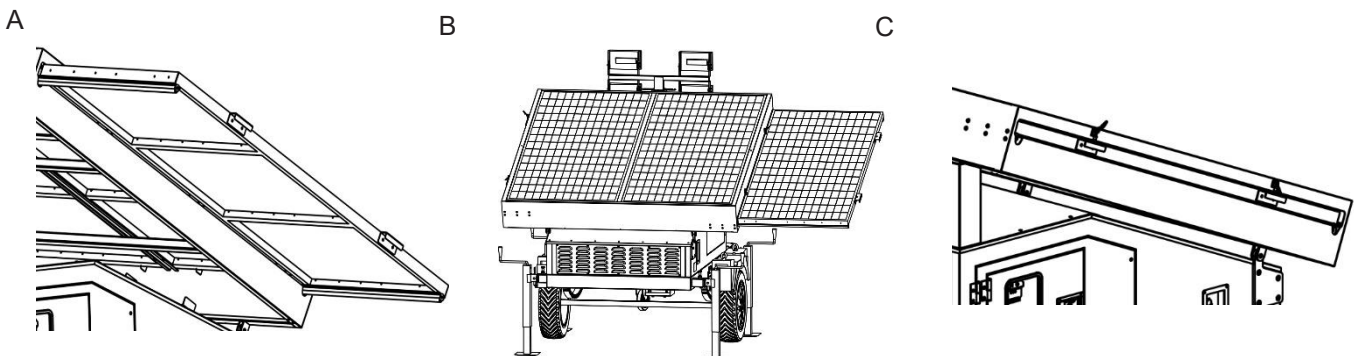

LOWERING THE MAST

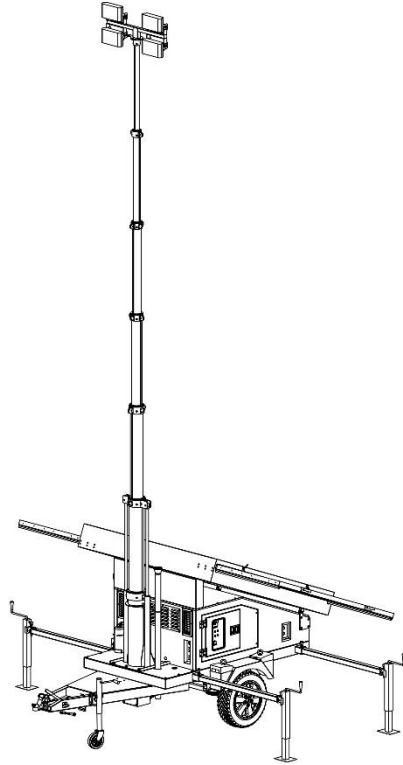

1. Check mast ropes for excessive wear or damage. Make sure the ropes are properly centered in each pulley.
2. Check the mast electrical cord for damage.

⚠WARNING

Do not operate the unit if the insulation on the electrical cord is cut or worn through. Bare wires in contact with the mast or frame may energize the trailer and cause electrocution. Repair or replace cord.

3. crank the manual winch in anti-clockwise direction(A), lower the mast to its original static height and make sure the steel rope is orderly (B).

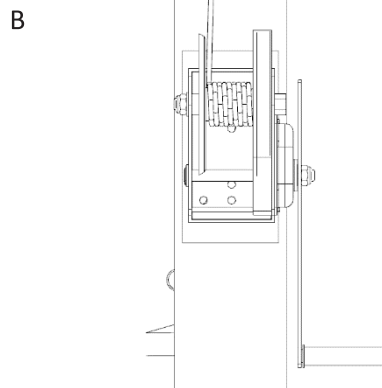
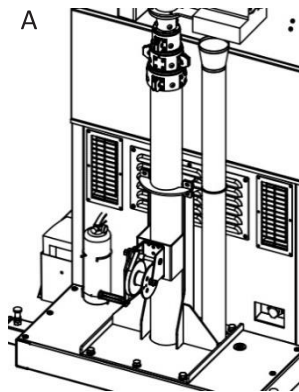

LOWERING THE MAST WITH MANUAL OR HYDRAULIC SYSTEM

1. Check mast ropes for excessive wear or damage. Make sure the ropes are properly centered in each pulley.
2. Check the mast electrical cord for damage.

⚠ WARNING

Do not operate the unit if the insulation on the electrical cord is cut or worn through. Bare wires in contact with the mast or frame may energize the trailer and cause electrocution. Repair or replace cord.

3. press the lower button on the electric winch controller, lower the mast to its original static height and make sure the steel rope is orderly (B).

⚠ CAUTION

On solar tower equipped with the electric winch option, a limit switch on the main mast section will disconnect power to the electric winch to prevent it from overextending.

A

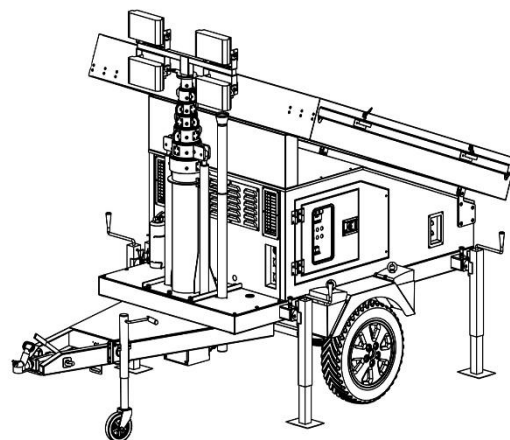
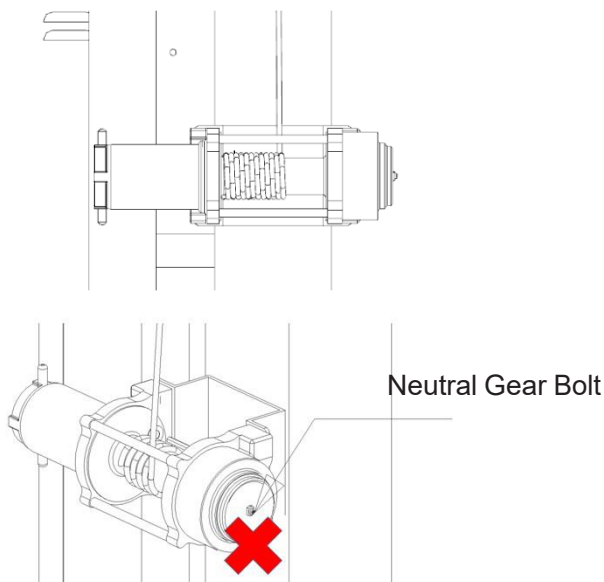

WARNING

When the mast is extended, do not operate the neutral gear bolt on the electric winch. It will lead to sudden falling of the mast and cause equipment damage and personal injury or death.

LOWER THE MAST WITH THE OPTIONAL HYDRAULIC

1. Check hydraulic oil, valve blocks, hydraulic cylinder, hoses and oil joints. Make sure there is no leakage and enough hydraulic oil in the tank.
2. Check the mast electrical cord for damage.

⚠ WARNING

Do not operate the unit if the insulation on the electrical cord is cut or worn through. Bare wires in contact with the mast or frame may energize the trailer and cause electrocution. Repair or replace cord.

3. Press the lower button on the hydraulic system controller and lower the mast to its original static height.

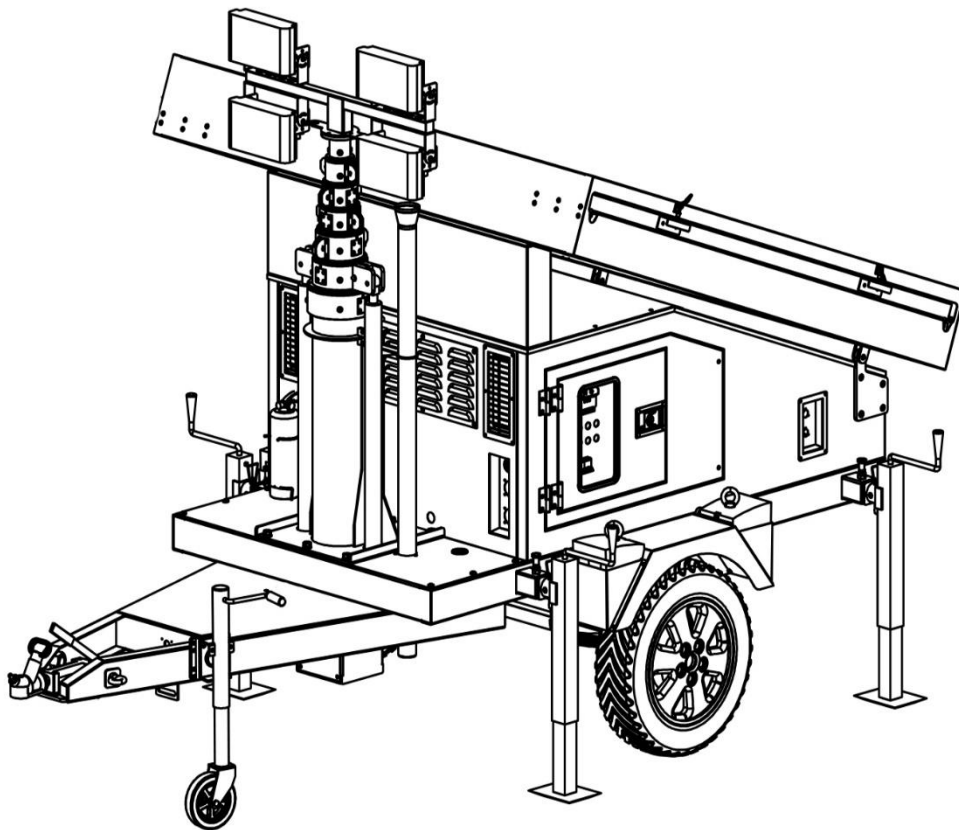

ELECTRICAL CIRCUIT DIAGRAM

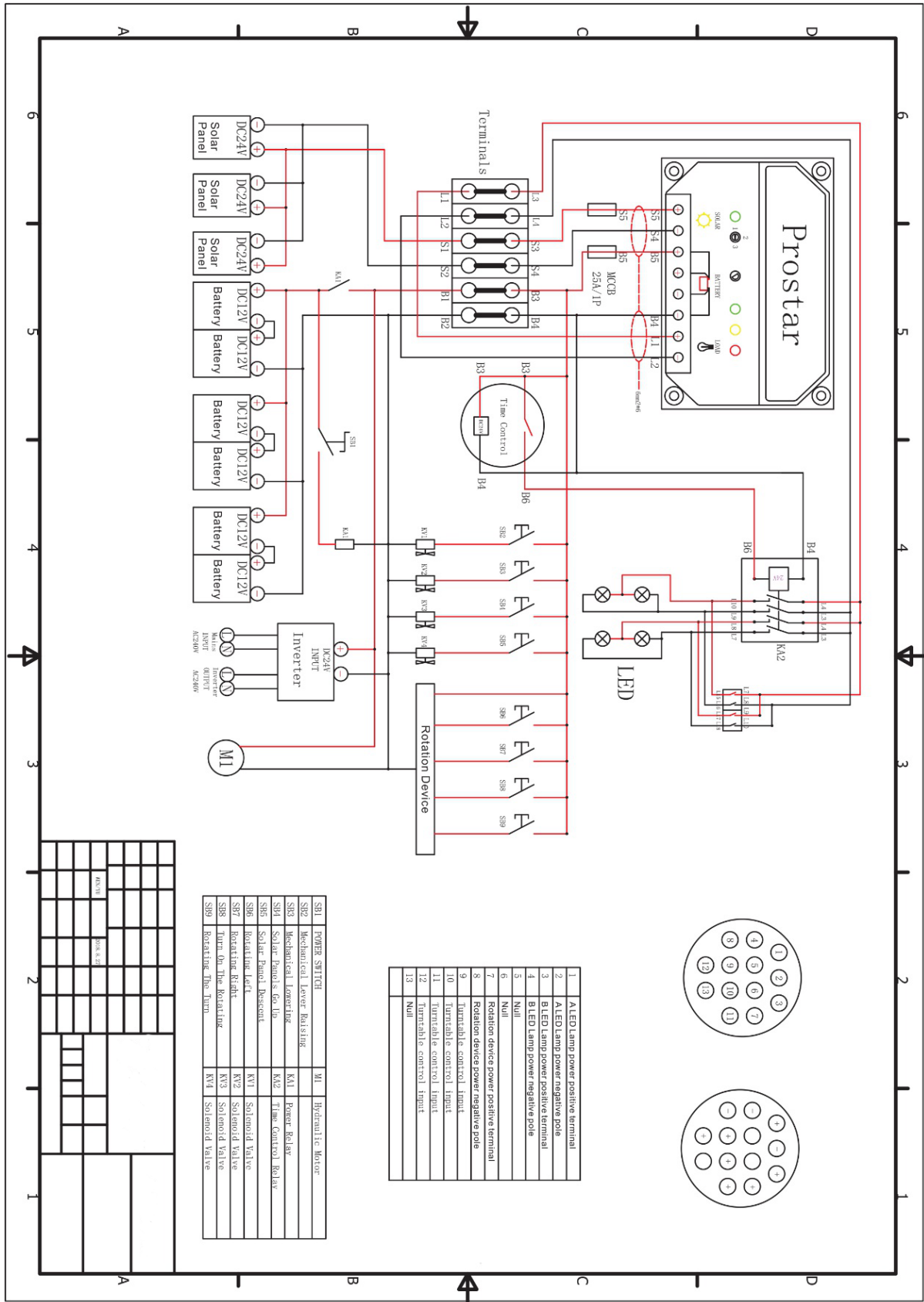

HYDRAULIC ELECTRICAL CIRCUIT DIAGRAM

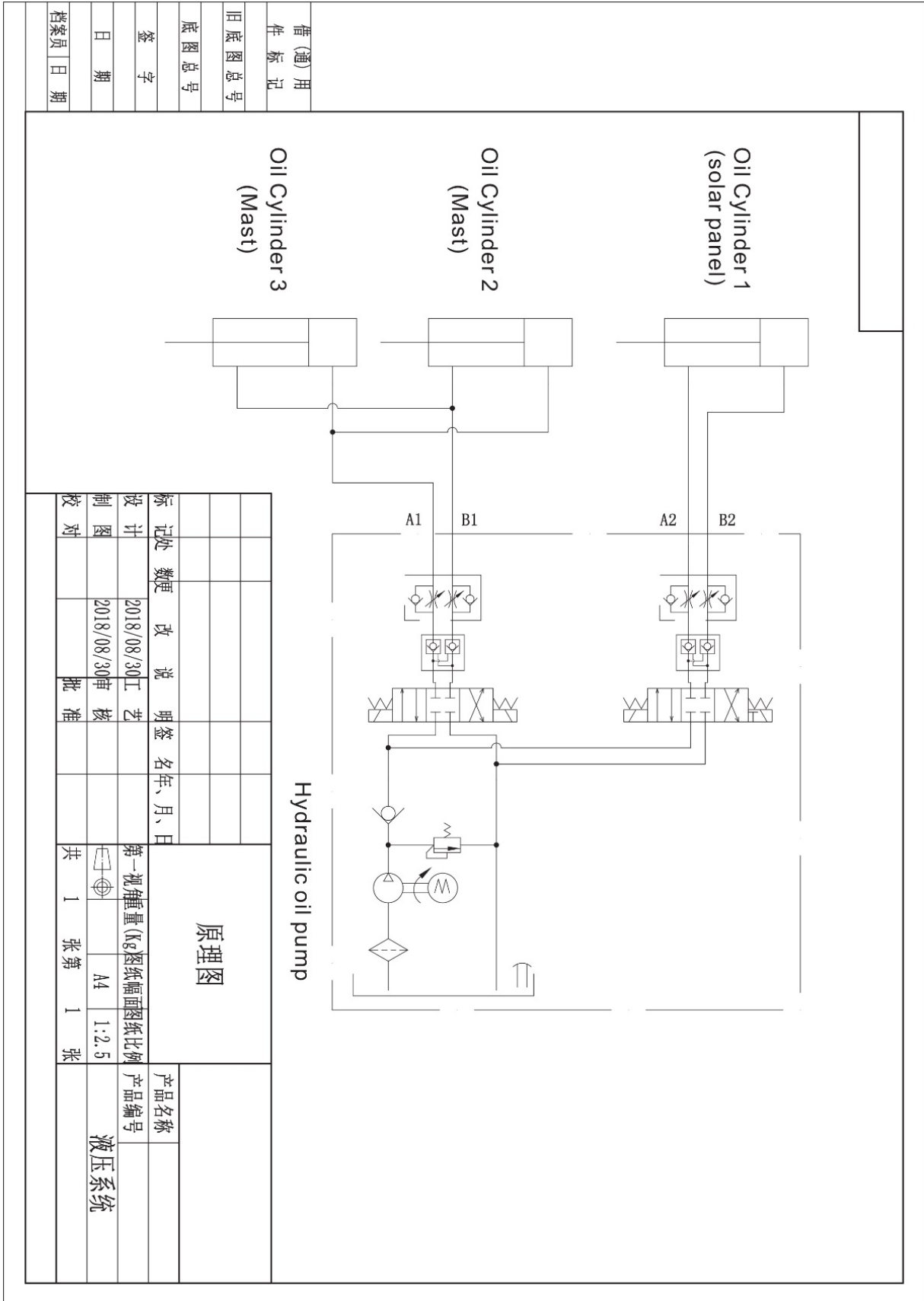

借(通)用 件 标 记
旧底图总号
底图总号
签 字
日 期
档案员 日期

原 理 图	
标 记 处 数 便 改 说 明 签 名 年、月、日	
设计	2018/08/30 王 艺 核 准
制 图	2018/08/30 审 批
校 对	
共 1 张 第 1 张	
第一视图量(Kg) 图幅面积 比例	产品名称
A4 1:2.5	产品编号
	液 压 系 统

TAIL LIGHT DIAGRAM

